

TASMANIAN PLANNING COMMISSION



Urgent Amendment HUO UA4-2017 Huon Valley Interim Planning Scheme 2015

1. Delete Residential as a Permitted use class in clause 12.2 Use Table.
2. Insert Diagrams 12.4.2A, 12.4.2B, 12.4.2C and 12.4.2D in the Low Density Residential Zone development standards, as follows:

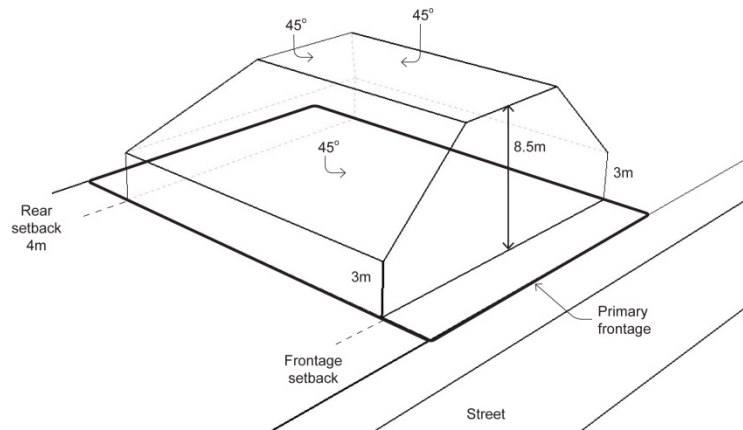

Diagram 12.4.2A Building envelope as required by subclause 12.4.2 A3(a).

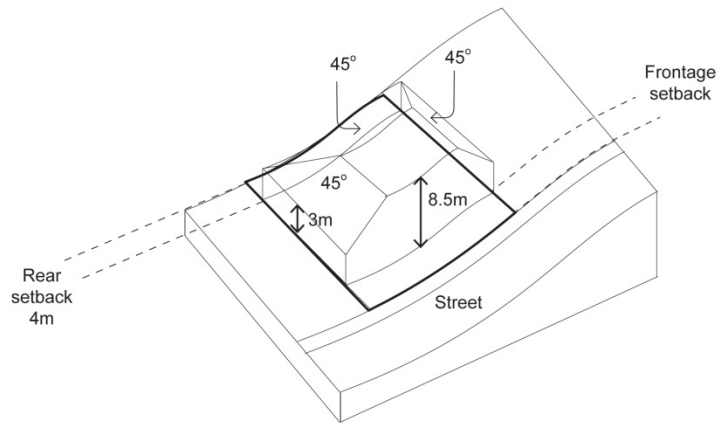
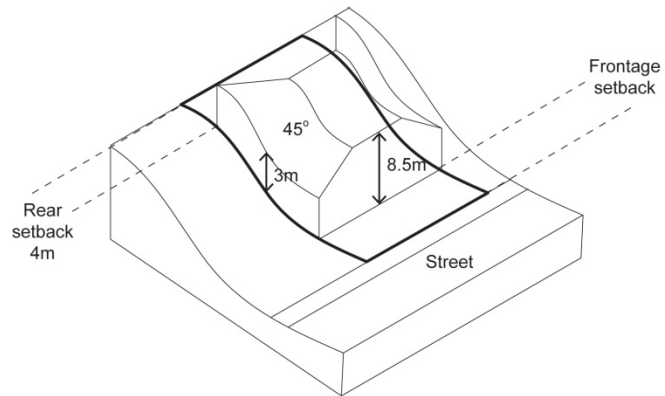

Diagram 12.4.2B Building envelope for sloping sites as required by subclause 12.4.2 A3(a).

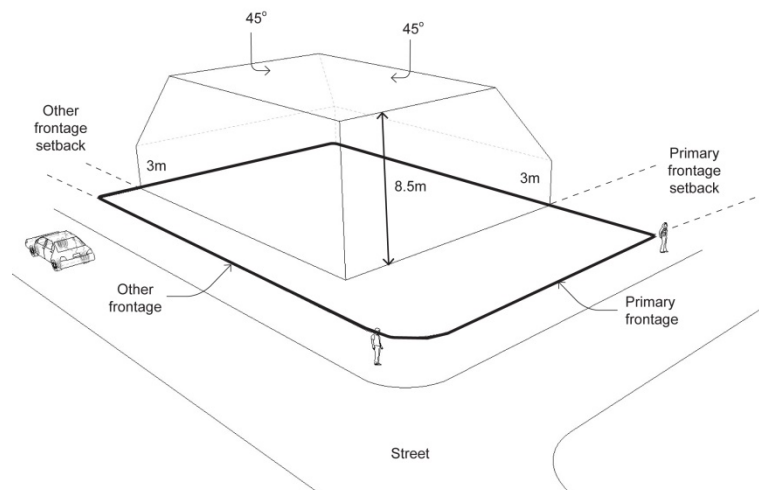

Diagram 12.4.2C Building envelope for corner lots as required by subclause 12.4.2 A3(a).

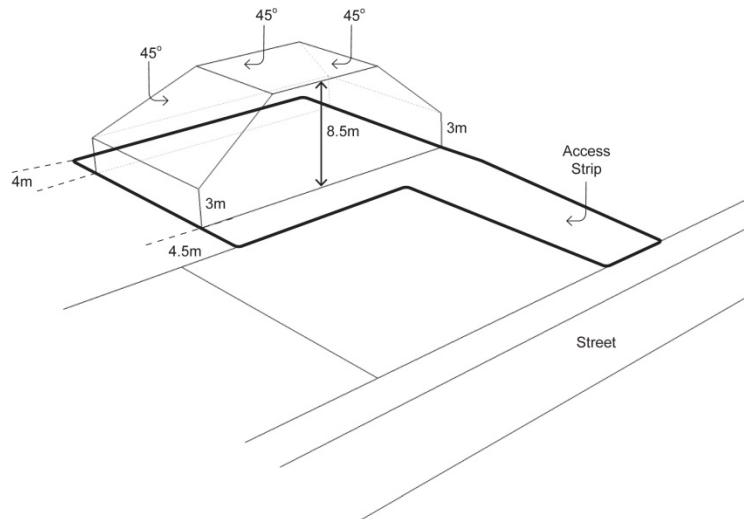

Diagram 12.4.2D Building envelope for internal lots as required by subclause 12.4.2 A3(a).

A handwritten signature in black ink, appearing to read "G. A. Alomes".

Greg Alomes
Executive Commissioner
Tasmanian Planning Commission

This amendment comes into effect on 25 May 2018